

SOCIALIZATION OF RFID-BASED SMART LOCK DOOR SYSTEM USING ESP32 AS A SECURITY SOLUTION IN THE LABORATORY ROOM OF SMAN 1 TAJURHALANG

Jati Kinsela Brajamusti¹, Ryanza Aufa Yansa², Maulana Ridhwan Riziq³, Aryaguna Abi Rafdi Yasa⁴, Ahmad Hidayatullah⁵, Sugeng Prayitno⁶

^{1,2,3,4,5,6}Electrical Engineering, Universitas Pembangunan Nasional Veteran Jakarta
2110314006@mahasiswa.upnvj.ac.id

Received 4th June 2024 | Revised 5th June 2024 | Accepted June 2024

ABSTRACT

The importance of security technology in educational environments has led to the implementation of an RFID-based Smart Lock Door system with ESP32 at SMAN 1 Tajurhalang. Socialization and education are key to ensuring effective understanding and application by students and staff. Interactive socialization activities and in-depth education about this system aim to increase awareness and understanding of extracurricular room security. The results showed a significant increase in participants' familiarity and knowledge, from 48% to 91.21%, after training. This increase demonstrates the effectiveness of socialization in changing attitudes and behaviors related to security in extracurricular spaces, creating a safe and conducive learning environment.

Keywords: security, RFID, Lock Door, safe

1. INTRODUCTION

Along with the rapid development of technology, security aspects have become a major concern, especially in educational environments such as school laboratories. At SMAN 1 Tajurhalang, the need for an effective and efficient security system to manage access to sensitive rooms is increasing. This has triggered the development of smart door systems or "smart door locks" based on Internet of Things (IoT) and Radio-Frequency Identification (RFID) technology.

Recent activities show that the application of IoT and RFID technology in smart door systems can provide innovative and safe solutions. This is in line with the values of national defense which emphasize the importance of maintaining the security and integrity of the nation. Defending the country is not only a military duty, but also the responsibility of all citizens, including maintaining the security of the educational environment. Efforts to increase security in the educational environment are also in line with the goals of Pancasila and Citizenship Education (PPKn), namely forming intelligent, capable and responsible citizens. Article 30

paragraph (1) of the 1945 Constitution of the Republic of Indonesia mandates that every citizen has the right and obligation to participate in state defense and security efforts.

The implementation of the smart door lock system at SMAN 1 Tajurhalang is expected to increase the sense of security and comfort for students, teachers and school staff. This reflects the values of responsible and solution-oriented leadership. Islamic religious values also emphasize the importance of maintaining security and integrity. In a hadith, Rasulullah SAW said, "Whoever wakes up in the morning with the intention of protecting the safety of the Muslims, then he is fighting jihad in the way of Allah SWT." (HR. Muslim). The development of this smart door lock system is also an embodiment of the Al-Qur'an verse Ali Imran verse 104 which orders Muslims to call for virtue and prevent evil.

In the context of leadership, the development of a technology-based security system is also a good learning tool for honing students' leadership skills. According to transformational leadership theory, an effective leader must be able to inspire and motivate his team to achieve common goals through innovation and positive change. By involving students in smart door lock system development projects, they not only learn about technology, but also about how to lead projects, make decisions, and work together in teams to achieve results that benefit the school community.

In designing and implementing a smart door lock system, updated Indonesian language rules will be applied consistently. This is important to ensure that the system is easy to understand and use by all parties. Our group activity aims to socialize and educate the use of an RFID-based smart door lock system using an ESP32 microcontroller in the laboratory room at SMAN 1 Tajurhalang. We will discuss the implementation of the latest technology in creating modern and effective security solutions, in line with the demands of the times.

Activities carried out by Maulana, Azriadi, and Musrido (2023) show that the ESP32 microcontroller can be an effective solution in designing an IoT-based smart door lock system. The ESP32 has advantages such as dual-core, Wi-Fi support, and Bluetooth, which allows control of smart door lock devices and communication with Android smartphones via the internet. Another activity by Bakhri, A. S., Suhada, K., & Kamaludin, K. (2021) uses the BLYNK application as a platform for controlling a smart door lock system via the internet network. In addition, Salim, Puji Susilo, and Manik (2021) integrated RFID technology with ESP32 to control door access based on information from E-KTP cards, which shows great potential in improving the security and efficiency of access systems.

By considering these findings, we are trying to design and implement a smart lock door system that suits the laboratory space needs at SMAN 1 Tajurhalang. This system is expected to be able to provide a higher level of security and better ease of use, in accordance with currently developing educational, security and technological values.

2. METHODOLOGY

This socialization is a Project-Based Learning activity which has a mission to solve the problem of pillar 4 of Strengthening National Resilience and Governance in achieving a Golden Indonesia 2045. This activity uses a qualitative approach to evaluate the effectiveness of socializing the RFID-based Smart Lock Door system using ESP32 as a security solution in the laboratory room at SMAN 1 Tajurhalang. Data was collected through participatory observation in the school environment with documentation in the form of photos and videos, as well as through completing pre-tests and post-tests by participants. The collected data was then analyzed inductively through three main steps.

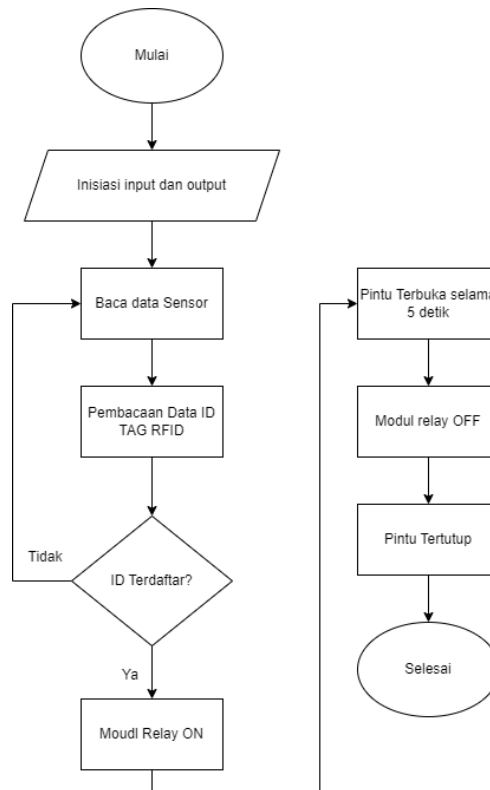

Figure 1 System Flowchart

Next, plans and strategies are prepared carefully, including tool design, supporting components, how the tool works, and the application of the Internet of Things (IoT) to the system. The main components used include the RC522 RFID module, ESP32 microcontroller, relay and solenoid lock. After planning, the tool is made by assembling electronic components such as the RFID module, ESP32 microcontroller, and solenoid lock according to the electronic circuit design. The ESP32 microcontroller is programmed to identify the RFID card and control the lock solenoid via relay. The tool casing is made using styrofoam to protect the electronic components and provide a neat appearance.

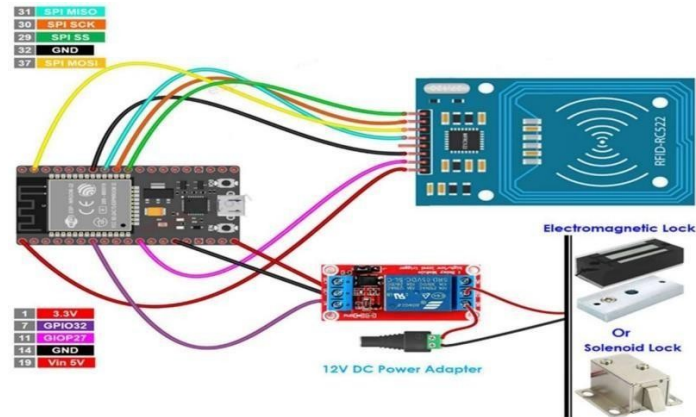

Figure 2 System Schematic Circuit

The implementation phase consists of socialization and demonstration of the tool to participants including students and supervisors. The socialization was carried out by providing material regarding the smart lock door system and its function as a security solution in the laboratory room, as well as collecting data through pre-tests and post-tests to measure participants' understanding before and after the socialization. The material presented includes the understanding and importance of security in laboratory spaces, an introduction to the smart lock door system and RFID technology, an explanation of the main components such as the ESP32 microcontroller, RC522 RFID module, solenoid lock and relay, how the IoT-based smart lock door system works, background to the creation this system, implementation of IoT in a smart lock door system, video of making and assembling the tool, as well as a direct demonstration of the use of the smart lock door system to participants.

Evaluation is carried out by collecting feedback from participants through questionnaires to evaluate the effectiveness of socialization and demonstration of the tool, as well as making adjustments if necessary. With this implementation method, it is hoped that participants can understand the importance of security in laboratory rooms and how the RFID-based smart lock door system works, as well as support the implementation of this system at SMAN 1 Tajurhalang.

3. RESULTS AND DISCUSSION

In this socialization, we obtained data from the data collection method in the form of a survey via the Google Form platform as follows.

Table 1 material understanding data

No.	Aspek	Evaluasi		Kenaikan
		Pre - test	Post-test	
1	Fokus pengembangan sistem	63,3%	90,9%	27,6%

2	Teknologi dasar alat	40 %	93,9%	53,9%
3	Manfaat ESP32	30 %	90,9%	60,9%
4	Akses pintu	26,7%	97%	70.3%
5	Tujuan sistem	83,3%	93,9%	10,6%
6	Tantangan alat	6,7 %	87,9%	81.2%
7	Inovasi sistem	70 %	93,9%	23.9%
8	Peran mikrokont roler	50 %	87,9%	37,9%
9	Manfaat alat	90 %	84,8%	-5,2%
10	Prioritas isu teknologi	20 %	90,9%	70,9%

Referring to the table above, 32 student responses showed 93.8% of the effectiveness of the tools made, which shows that during the socialization, the tools provided were very effective, there are case studies that they experienced regarding laboratory safety. This is also supported by graphics 4 which explain students' opinions regarding the tool created, namely the smart door lock.

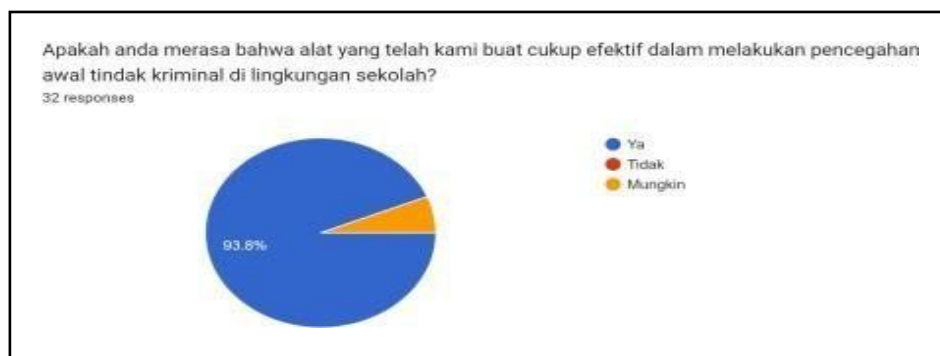

Figure 3 Graph of student responses to the effectiveness of the tool

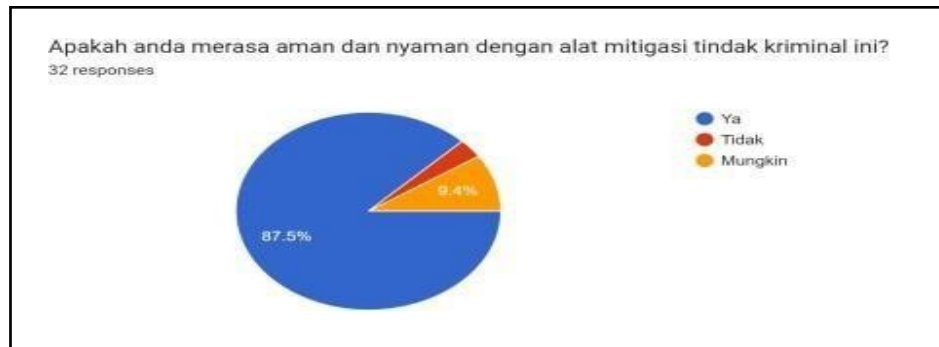

Figure 4 Graph of students' opinions on the tool

and not only that, 32 student responses also stated that 75% agreed to apply this solution in their home environment, this is proven in the Figure 5 This shows the high level of enthusiasm and interest among students in the tool solution that we provide.

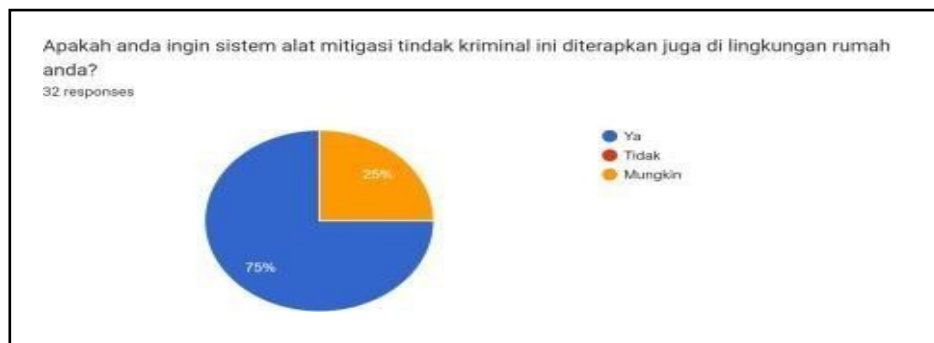

Figure 5 Graph of students' opinions regarding the implementation of tools at home

The following is data on opinions and understanding of the material from the socialization activity for the Internet of Things-based smart lock door system at SMA Negeri 1 Tajurhalang. In this socialization, students' knowledge about the application of the smart lock door system was measured before and after the socialization activity. The pre-test results showed that the participants' initial level of familiarity with this system was on average 48%.

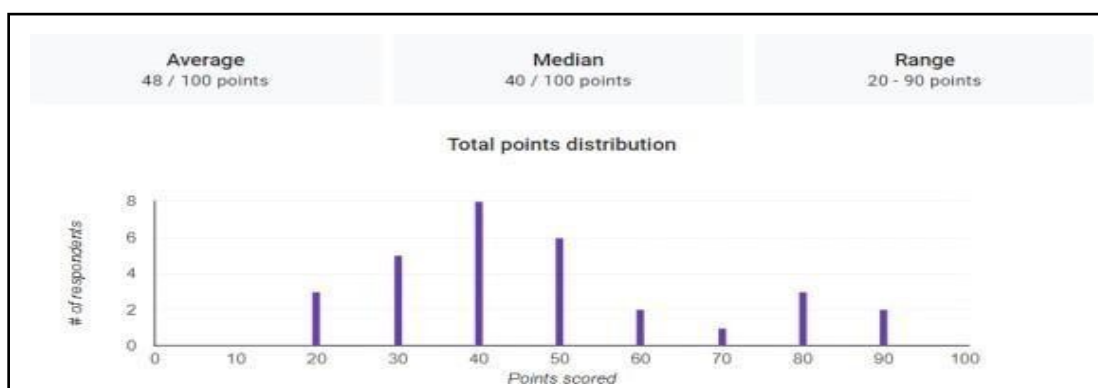

Figure 6 Graph of distribution of average pre-test scores

However, after participating in training activities, the students' familiarity level increased significantly to 91.21%, indicating an increase of 43.21%. In addition, the data also shows significant changes in students' knowledge about implementing the smart door lock system. Before socialization, most students had limited knowledge and pessimistic views about the benefits of implementing this system.

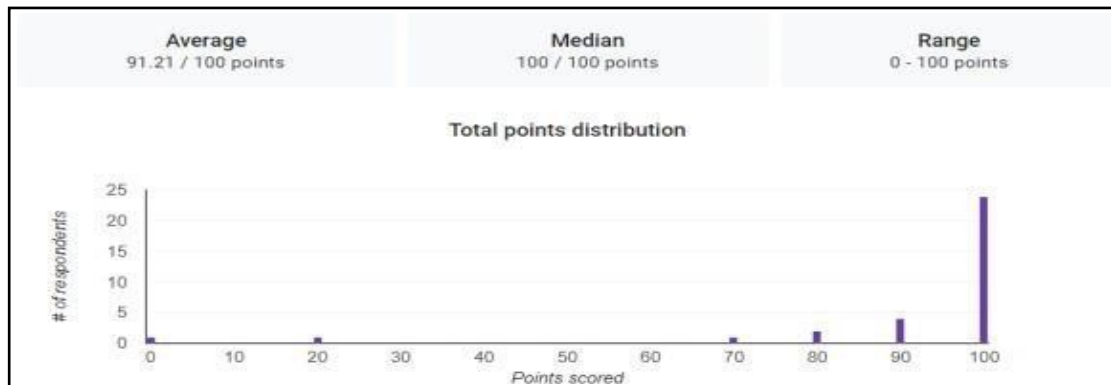

Figure 7 Graph of distribution of average post-test scores

4. CONCLUSION

After carrying out outreach activities regarding the RFID-based smart lock door system using ESP-32 as a security solution in the laboratory room at SMAN 1 Tajurhalang, it can be concluded that students have become more understanding and aware of maintaining the security of the laboratory room. Students' knowledge increased from 48% to 91.21% regarding the implementation of an RFID-based smart door lock system using ESP-32 as a security solution in the laboratory room at SMAN 1 Tajurhalang. From these results, it can be concluded that this socialization activity was effective in increasing participants' knowledge and familiarity with the application of the smart door lock system. Positive views on the benefits of implementing this system also increased significantly after the training, indicating the effectiveness of the training in changing student perceptions.

REFERENCES

- Maulana, I., Azriadi, E., & Musrido, J. (2023). Rancang Bangun Sistem Smart Door Lock Menggunakan Mikrokontroler Esp32 Berbasis Internet Of Things (Iot) dan Smartphone Android. *Jurnal Teknik Industri Terintegrasi (JUTIN)*, 6(1), 195-208.
- Bakhri, A. S., Suhada, K., & Kamaludin, K. (2021, September). Perancangan Sistem Doorlock Menggunakan Aplikasi Blynk Berbasis IoT Studi Kasus Pada Rumah Tempat Tinggal Pribadi. In *Prosiding Seminar Nasional Inovasi Dan Adopsi Teknologi (INOTEK)* (Vol. 1, No. 1, pp. 1-10).
- Salim, D. N., Pujisusilo, N. A., & Manik, S. P. (2021). Sistem Keamanan Smart Door Lock Menggunakan E-KTP (Elektroknik Kartu Tanda Penduduk) Berbasis Internet of Things (IoT). *Go Infotech: Jurnal Ilmiah STMIK AUB*, 27(2), 196-206.

- Firmansyah, R. H., & Mukmin, C. (2023). Sistem Smart Lock Door Berbasis Internet of Things (IoT) Menggunakan ESP32. *INTECOMS: Journal of Information Technology and Computer Science*, 6(2), 879-884.
- Abdilah, R. I. (2022). Penerapan Sistem keamanan Smart Door Lock Berbasis Internet of Things (IoT) Pada Ruang Server di Puslitbangnak.
- Rizky, R. F., Zy, A. T., & Sunge, A. S. (2023). Sistem Smart Door Lock Menggunakan Voice Recognition Berbasis Arduino. *Bulletin of Information Technology (BIT)*, 4(2), 239-244.
- Hakim, M. L., Yuniarto, I., & Mutaqin, M. Z. (2023). System Smart Door Lock Pada Ruang Lab Komputer SMA Muhammadiyah 9 Kota Bekasi Berbasis Arduino Nano. *Jupiter: Journal of Computer & Information Technology*, 4(1), 38-47.
- Nurindini, T., Swacaesar, M. N., Astika, R. W., Purwanto, H., Wijayanti, R. A., & Taufik, M. (2023). Design of Smart Door Lock System Using Face Recognition and Mask Detection Based on Viola-Jones Algorithm with Android Integration. *Journal of Telecommunication Network (Jurnal Jaringan Telekomunikasi)*, 13(1), 1-8.
- Yuniarto, A. H. P., Lestiyanti, Y., Asrori, M. F., Laela, N., & Nurcholis, A. (2023). Perancangan Smart Door Lock System dengan Multi Sensor untuk Sistem Keamanan Rumah. *Techné: Jurnal Ilmiah Elektroteknika*, 22(2), 333-342.

ACKNOWLEDGEMENT

We express our gratitude to the presence of Allah SWT, who has given us His mercy and grace so that the author can complete the tasks of this project and article as an effort to implement PjBL (Project Base Learning) as a collaborative project between general compulsory courses at the Veterans National Development University, Jakarta. We would like to express our deepest gratitude to Mr. Ahmad Hidayatullah, M.Pd. and Mr. Prof. Dr. Arono, M.Pd. as Indonesian language lecturer, Mr. Dr. Faisal Marzuki, M.Pd. and Mrs. Dr. Ilona Vicenovie Oisina S. as leadership lecturer, Mrs. Ir. Sri Sulasminingsih, MSi. and Mr. Dr. Edyson Cholia, MM. as a lecturer on Pancasila and Citizenship, Mrs. Dr. Ernalem Bangun, MA and Mr. Ir. Sugeng Prayitno, M.T. as a lecturer in National Defense Education, Mr. Sayuti Hamdani, S.Pd.I., MA and Mr. Dr. Nurjanah, MA as a lecturer in Islamic Religious Education, as well as members of KIR, OSIS and supervisors of SMAN 1 Tajurhalang who were present, colleagues from group 2 of PJBL, and everyone who helped in the success of making our project assignments and articles.